

Telescopic Crane

HC 190

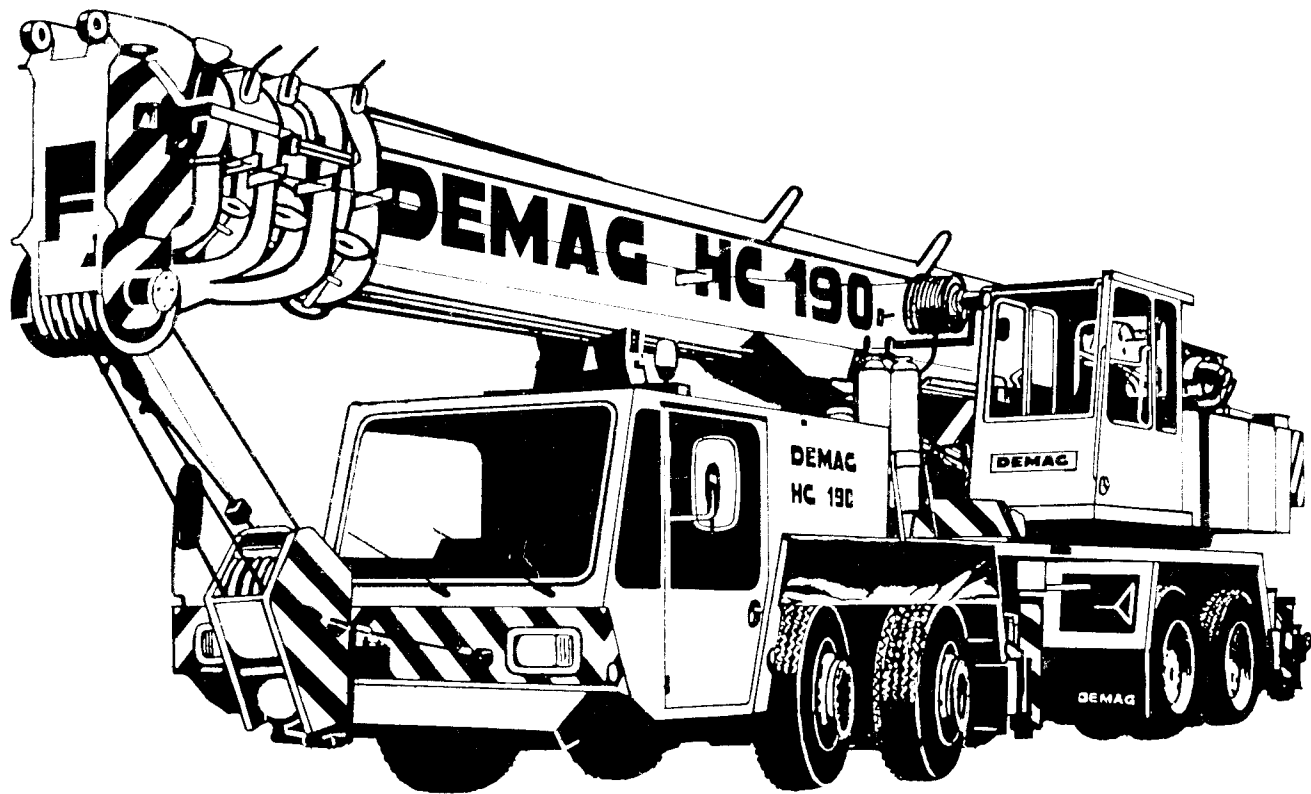

Dimension Chart

Demag HC 190 83 Ton

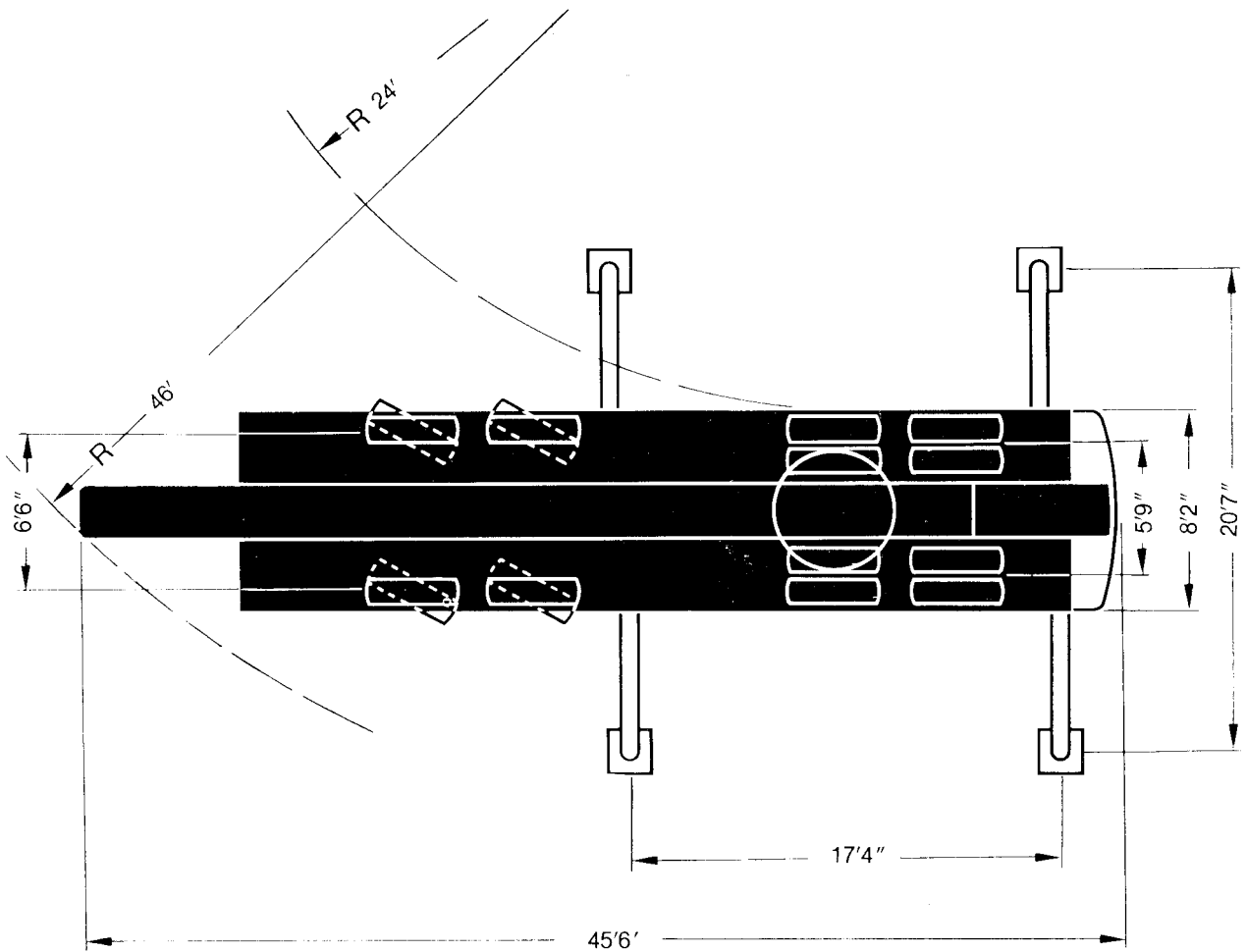
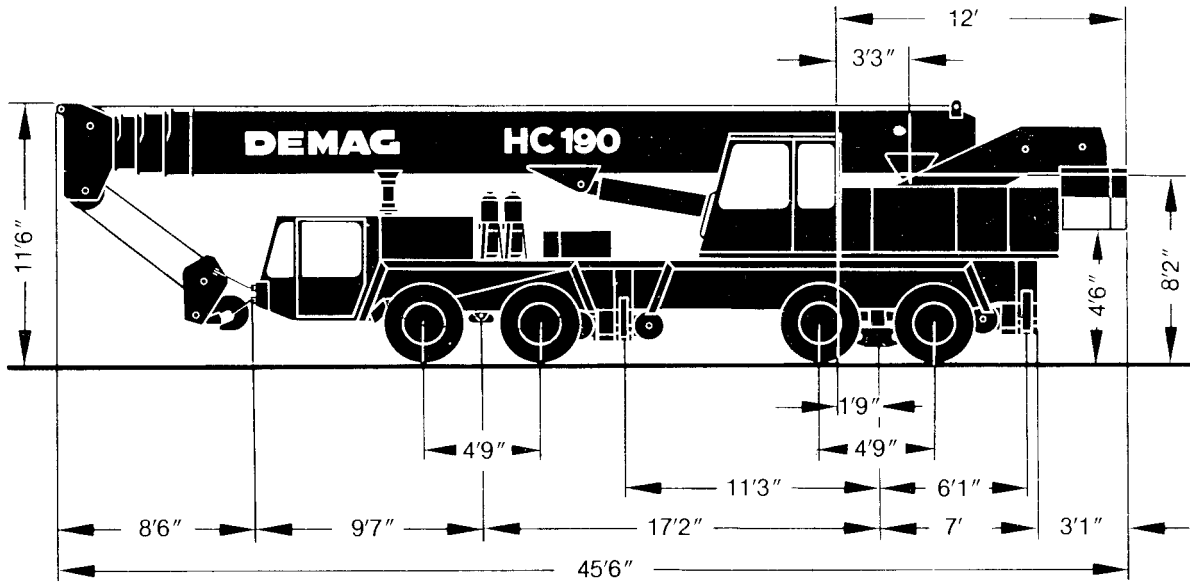

Axle Loads

Crane with Main Boom, 2nd Hoist Drum, (Carrier 8x4)	
Front Axles	2 x 16,000 lbs
Rear Axles	2 x 22,000 lbs
Total Axle Load	76,000 lbs

Working Speeds (infinitely variable)

Units	Normal	High Speed	Rope Pull, Single Line	Length of Hoist Rope
Main Hoist	164-328 ft/min	230-459 ft/min	85% 12,313 lbs (6 t)	886 ft
Secondary Hoist	164 ft/min		11,194 lbs (5.5 t)	574 ft
Swing	max. 3 RPM			
Telescoping Speed 35.8-121.4 ft	80 sec			
Boom Elevation from — 2° to 80°	60 sec			

Carrier Performance

Travel Speeds	Reverse	3.8 miles/hr	Forward	3.4...4.4 miles/hr
Lowest Speed at Maximum Torque	(1.8 miles/hr)*			2.1 miles/hr
Gradeability in Travel Order	(44,1%)*			max. 28,1%

* (235 kW) Daimler-Benz OM403

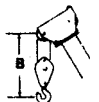

Hook-Block/Crane Hook

Capacity	85%	Number of Sheaves	Number of Lines	Weight	"B"
	83 t	7	14	1195 lbs	5.6 ft
	55 t	4	9	937 lbs	5.2 ft
	22 t	1	3	507 lbs	5.2 ft
	6 t	Crane Hook	1	353 lbs	4.9 ft

Working Ranges of Main and Extension Booms

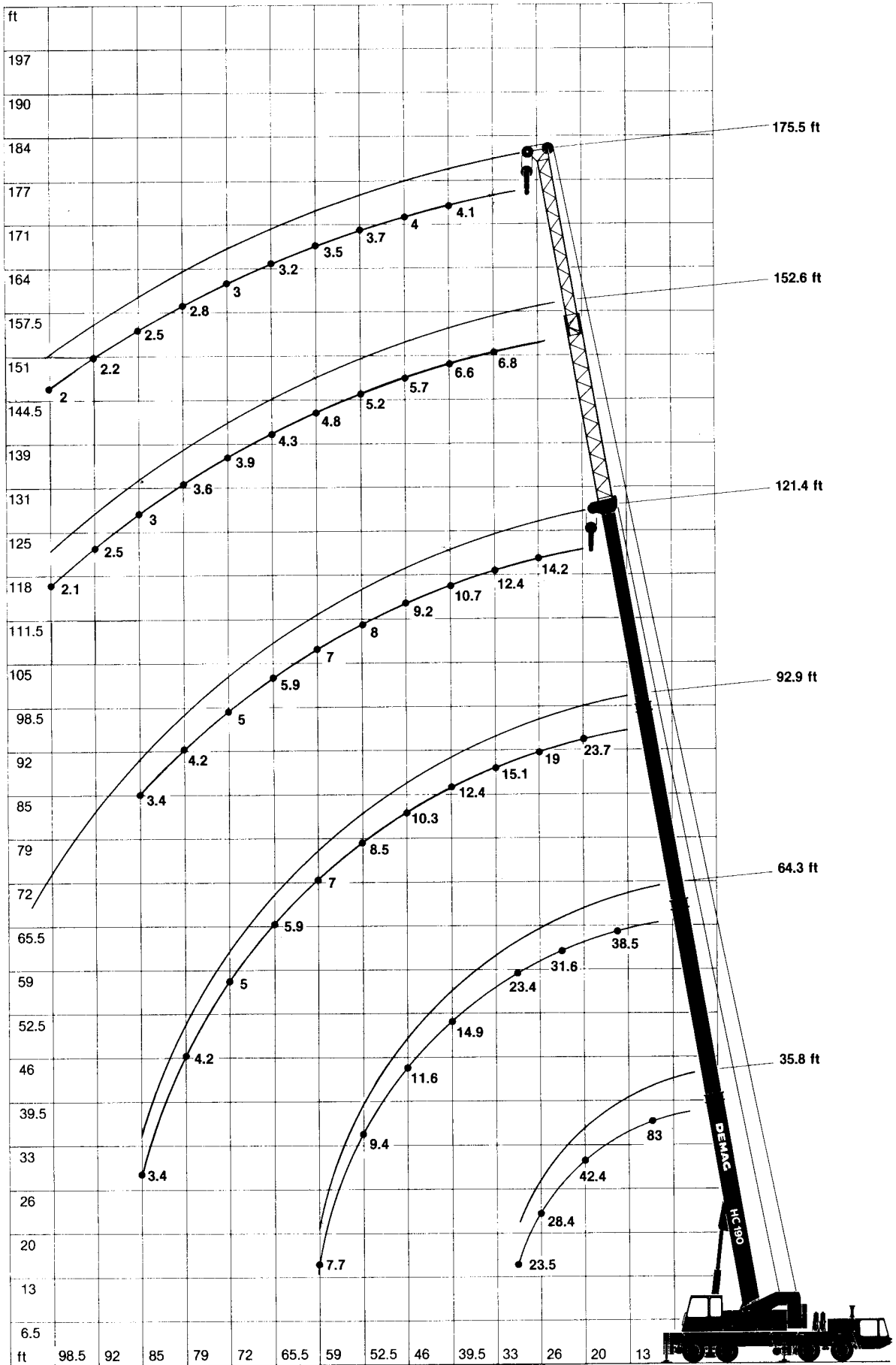







Lifting Capacities on Main Boom

14 t Counterweight

 free on tires

 with outriggers

85%

Radius	Main Boom				121.4 ft Main Boom			Radius
	35.8 ft	64.3 ft	92.9 ft	121.4 ft	35.8 ft	Extension Boom		
					over rear 	31 ft (152.6 ft) 	54 ft (175.5 ft) 	
ft.	t	t	t	t	t	t	t	ft.
9.8	83	—	—	—	19.4	—	—	9.8
11.5	73.4	—	—	—	15.7	—	—	11.5
13	63.4	—	—	—	13.1	—	—	13
14.8	56.5	38.5	—	—	11.1	—	—	18
16.5	51.2	37.4	—	—	9.7	—	—	16.5
20	42.4	34.9	23.7	—	7.5	—	—	20
23	35.4	31.6	21.6	14.9	5.9	—	—	23
26	28.4	28.3	19	14.2	4.8	—	—	26
29.5	23.5	23.4	16.8	13.4	4	6.8	—	29.5
33	—	19.8	15.1	12.4	—	6.6	—	33
39.5	—	14.9	12.4	10.7	—	6.2	4.1	39.5
46	—	11.6	10.3	9.2	—	5.7	4	46
52.5	—	9.4	8.5	8	—	5.2	3.7	52.5
59	—	7.7	7	7	—	4.8	3.5	59
65.5	—	—	5.9	5.9	—	4.3	3.2	65.5
72	—	—	5	5	—	3.9	3	72
79	—	—	4.2	4.2	—	3.6	2.8	79
85	—	—	3.4	3.4	—	3	2.5	85
92	—	—	—	2.9	—	2.5	2.2	92
98.5	—	—	—	2.3	—	2.1	2	98.5
105	—	—	—	—	—	1.7	1.7	105
111.5	—	—	—	—	—	1.3	1.5	111.5
118	—	—	—	—	—	0.9	1.4	118

— The capacities above the parting line are based upon the structural strength. The ratings below the parting line are based on stability for the percentage of tipping load indicated.

Crane Capacity Notes

The lifting capacities do not exceed 85%/75% of tipping load.

Wind pressures considered:

85% ratings: 50.85 ft/sec or 35 mph

75% ratings: 66 ft/sec or 44 mph

Crane operation up to a wind force of 29.5 ft/sec or 20 mph permissible.

The 75% ratings comply with Din 15019.2 (test load = 1.25 x lifting load + 0.1 x dead weight of boom reduced to boom point).

The weights of all load-handling devices are considered part of the load, and suitable allowance for them should be made.

Jib-Boom Working Ranges

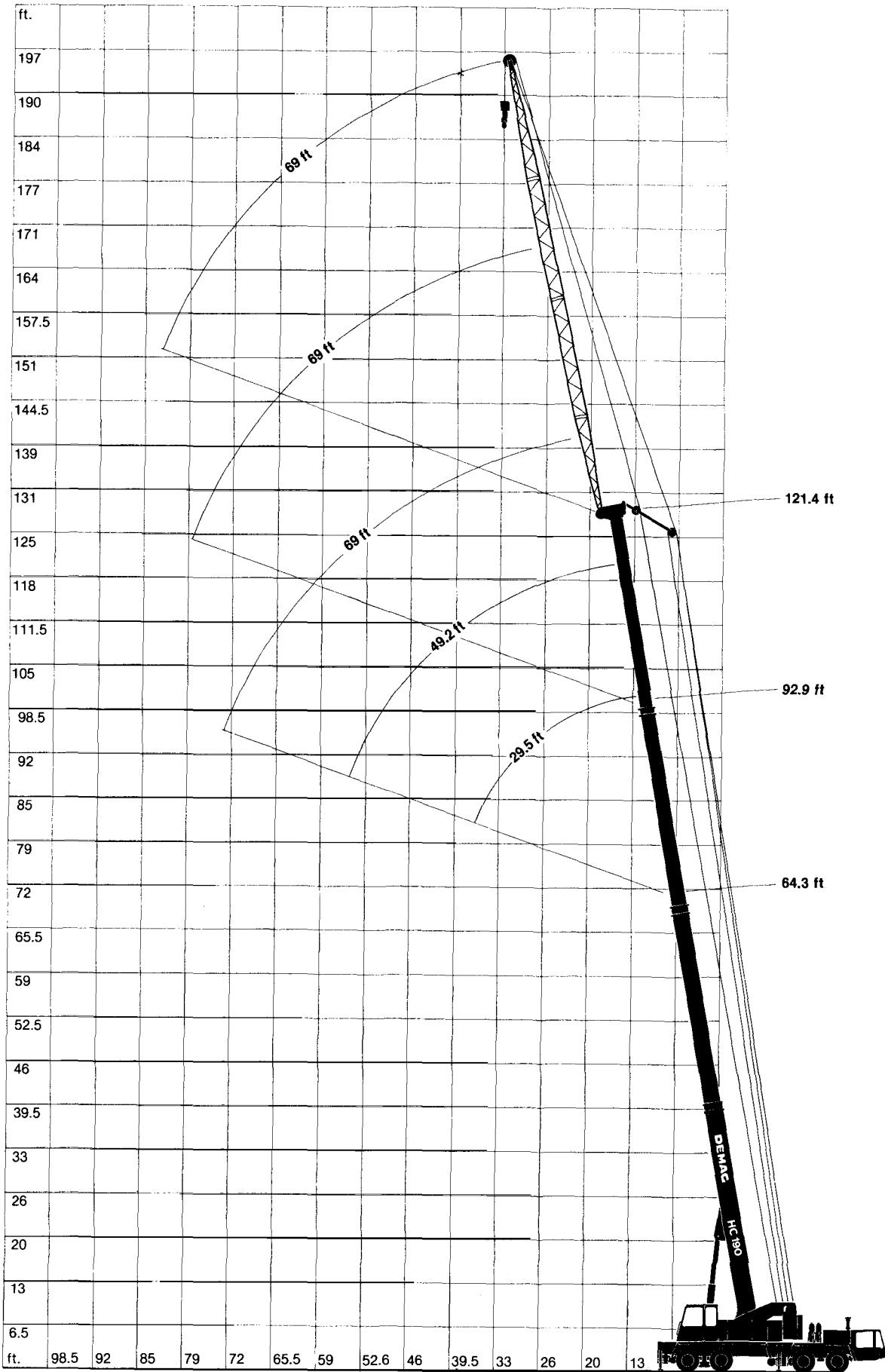

Carrier

Truck-Type Carrier

Make: Demag
Drive: 8 x 4

Frame

Demag-built monobox main frame with outrigger boxes integral, of high-grade close-grained steel.

Outriggers

Four hydraulically telescoping outrigger beams with hydraulic jack legs.

Engine

Daimler-Benz OM-402 water-cooled 8-cylinder diesel engine.
Output to DIN 70020: 188 kW (256 HP)
Fuel-Tank Capacity: 79 gallons

Main Clutch

Air/oil-actuated single-plate dry-type clutch.

Transmission

ZF 8-speed plus creeper range forward, one reverse main transmission.

Axles

Make: Daimler-Benz
1st and 2nd: steering, non-driving, with single tires; suspended from articulated laminated springs.
3rd and 4th: driving, non-steering, with dual tires, planetary hubs, and differential with lock-out control lengthwise and transverse. Walking-beam suspension.

Wheels and Tires

12 disk-type wheels 9.25 x 22.5 fitted with 13R 22.5 tires, plus 1 spare.

Steering

ZF semibloc mechanical steering with hydraulic booster.

Brakes

to EC standards.

Electrical Equipment

24-volt system.

Cab

Rubber-mounted low-line two-man all-steel cab.

Superstructure

Upper Frame

Demag-built weldment of high-grade close-grained steel.

Paneling

Sectional side panels, removable for service accessibility.

Turntable Mounting

Triple-row roller-bearing swing circle with external ring gear.

Engine

Klöckner-Humboldt-Deutz F6L-912 air-cooled 6-cylinder diesel engine.
Output to DIN 6270B: 74 kW (100 HP).
Fuel-Tank Capacity: 74 gallons.

Hydraulic System

3 variable-displacement axial-piston hydraulic pumps (enable the operator to engage three motions at the same time through fingertip hydraulic controls). 1 gear-type hydraulic pump for the low-pressure circuit.

Hoist

Variable displacement axial-piston hydraulic motor with planetary reduction, and spring-loaded multi-disk brake in hoist drum.

Swing

Axial-piston hydraulic motor with planetary reduction.
Foot-pedal operated swing brake and spring-loaded holding brake.

Boom Elevation

One hydraulic cylinder with pilot controlled lowering brake valve.

Control

Four self-centering levers control all crane operations through hydraulic power and pilot valves.

Cab

Comfortable all-steel cab with large folding-out front and roof windows, and a sliding door. Hot-air heating unit and ventilation system.

Boom

Four-section fully synchronized power-telescoping boom, fabricated from high-grade close-grained plate stock, featuring the familiar DEMAG "ovaloid" design of rectangular box members with rounded-off corners. Each center section slides on self-centering diagonally arranged plastic shoes. Telescoping action comes from synchronized hydraulic cylinders.

Safety Devices

Electronic overload cut-out (load limiting device) of Demag design, with safe-load indicator; hoist and load lowering limit switches, relief and safety holding valves.

Optional Equipment

8 x 4 Carrier

with Daimler-Benz OM-403 water-cooled 10-cylinder diesel engine.
Output to DIN 70020: 235 kW (320 PS)
2-speed transfer case.

8 x 6 Carrier

with Daimler-Benz OM-403 water-cooled 10-cylinder diesel engine.
Output to DIN 70020: 235 kW (320 HP).
2-speed transfer case; 1st front axle steering and driving, with transverse differential and lock-out control, single tires, and planetary hubs.

Sprung Rear Axles

Walking-beam suspended tandem rear-axle unit with horizontally arranged helical springs and axle-load equalizers, for road speeds over 40 miles/hr. This DEMAG-built suspension makes rear-axle stabilizers unnecessary.

Hydraulic Front-Axle Stabilizers

in lieu of spacing bars to lock the sprung front axles for crane duty.

2nd Hoist Drum

Permits tandem lifts and avoids rereveing of hoist line when using the optional extension boom and luffing jib-boom. It is indispensable for jib-boom luffing.

The drum is powered by a fixed-displacement axial-piston hydraulic motor, through a planetary gear train, and equipped with a spring-loaded multi-disk brake.

Extension Boom

Manually telescoping 31 ft. to 54 ft. two-section fold-away lattice-type extension boom.

Luffing Jib-Boom

29.5 ft. two-part basic jib-boom with luffing mast and optional 19.7 ft. inserts to give a maximum jib-boom length of 69 ft. (the second hoist drum is required when using a luffing jib-boom).

Tow Coupling

13.2 t capacity; plus air-brake coupling.